

CHAPTER TWENTY-ONE

Non-Obviousness

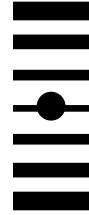

Introduction

Non-obviousness is in many ways the heart of the patent system, the place where we draw the most important line between sub-patentable and patentable innovation. As you learned in the previous chapter, lack of novelty—or “anticipation”—is a complete bar to patentability. Yet as we saw in that chapter, for an invention to be anticipated, every element of it needs to be present in a single prior art reference. The person alleging anticipation is effectively saying “we’ve already got it” and the “it” is a single thing.

Obviousness is different. The person alleging that an invention is obvious is not necessarily saying it already exists. She is saying that it consists of a trivial recombination of elements of the prior art, that a Person Having Ordinary Skill in The Art (or PHOSITA) would have been able to make the leap from those prior art references to come up with the new invention. This is an inherently synthetic task. It requires us to consider a counterfactual—to put ourselves in the shoes of an imaginary PHOSITA before the new invention, to consider all the resources in the art that would have been available to that person, as well as the nature of the problem to be solved, and then to ask the question “was this combination of elements obvious”?

§ 103 Conditions for patentability; non-obvious subject matter.¹

A patent for a claimed invention may not be obtained, notwithstanding that the claimed invention is not identically disclosed as set forth in section 102, if the differences between the claimed invention and the prior art are such that the claimed invention as a whole would have been obvious before the effective filing date of the claimed invention to a person having ordinary skill in the art to which the claimed invention pertains. Patentability shall not be negated by the manner in which the invention was made.

The story of the non-obviousness statutory requirement is rooted in some wrangling between the courts and Congress. The courts, led by the Supreme Court, had set out tests for what counted as a patentable invention that many believed to be too high. Some referred to them as requiring “a flash of genius.” Congress responded by passing the predecessor of § 103. It was the interpretation of that section, and the analysis of whether it trampled on constitutionally forbidden territory, that was at stake in a case you have read before, *Graham v. John Deere*. We will be interested to see if your reaction to that case is different when you read it in the specific context of non-obviousness.

¹ [USPTO Editor’s Note: Applicable to any patent application subject to the first inventor to file provisions of the AIA (see 35 U.S.C. 100 (note)). See 35 U.S.C. 103 (pre-AIA) for the law otherwise applicable.]

Graham v. John Deere Co.
383 U.S. 1 (1966)



Mr. Justice CLARK delivered the opinion of the Court.

After a lapse of 15 years, the Court again focuses its attention on the patentability of inventions under the standard of Art. I, § 8, cl. 8, of the Constitution and under the conditions prescribed by the laws of the United States. Since our last expression on patent validity, *Great A.&P. Tea Co. v. Supermarket Equipment Corp.* (1950), the Congress has for the first time expressly added a third statutory dimension to the two requirements of novelty and utility that had been the sole statutory test since the Patent Act of 1793. This is the test of obviousness, i.e., whether ‘the subject matter sought to be patented and the prior art are such that the subject matter as a whole would have been obvious at the time the invention was made to a person having ordinary skill in the art to which said subject matter pertains. Patentability shall not be negated by the manner in which the invention was made.’ 35 U.S.C. § 103.

The questions, involved in each of the companion cases before us, are what effect the 1952 Act had upon traditional statutory and judicial tests of patentability and what definitive tests are now required. We have concluded that the 1952 Act was intended to codify judicial precedents embracing the principle long ago announced by this Court in *Hotchkiss v. Greenwood* (1851) and that, while the clear language of § 103 places emphasis on an inquiry into obviousness, the general level of innovation necessary to sustain patentability remains the same.

I.

The Cases.

(a). No. 11, *Graham v. John Deere Co.*, an infringement suit by petitioners, presents a conflict between two Circuits over the validity of a single patent on a ‘Clamp for vibrating Shank Plows.’ The invention, a combination of old mechanical elements, involves a device designed to absorb shock from plow shanks as they plow through rocky soil and thus to prevent damage to the plow. In 1955, the Fifth Circuit had held the patent valid under its rule that when a combination produces an ‘old result in a cheaper and otherwise more advantageous way,’ it is patentable. *Jeoffroy Mfg., Inc. v. Graham*. In 1964, the Eighth Circuit held, in the case at bar, that there was no new result in the patented combination and that the patent was, therefore, not valid. We granted certiorari. Although we have determined that neither Circuit applied the correct test, we conclude that the patent is invalid under § 103 and, therefore, we affirm the judgment of the Eighth Circuit. . . .

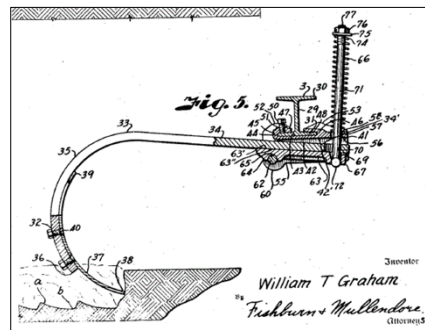

An image from Graham’s patent

II.

At the outset it must be remembered that the federal patent power stems from a specific constitutional provision which authorizes the Congress ‘To promote the Progress of * * * useful Arts, by securing for limited Times to * * * Inventors the exclusive Right to their * * * Discoveries.’ Art. I, s 8, cl. 8. The clause is both a grant of power and a limitation. This qualified authority, unlike the power often exercised in the sixteenth and seventeenth centuries by the English Crown, is limited to the promotion of advances in the ‘useful arts.’ It was written against the backdrop of the practices—eventually curtailed by the Statute of

Monopolies—of the Crown in granting monopolies to court favorites in goods or businesses which had long before been enjoyed by the public. The Congress in the exercise of the patent power may not overreach the restraints imposed by the stated constitutional purpose. Nor may it enlarge the patent monopoly without regard to the innovation, advancement or social benefit gained thereby. Moreover, Congress may not authorize the issuance of patents whose effects are to remove existent knowledge from the public domain, or to restrict free access to materials already available. Innovation, advancement, and things which add to the sum of useful knowledge are inherent requisites in a patent system which, by constitutional command, must “promote the Progress of * * * useful Arts.” This is the *standard* expressed in the Constitution, and it may not be ignored. And it is in this light that patent validity “requires reference to a standard written into the Constitution.”

Within the limits of the constitutional grant, the Congress may, of course, implement the stated purpose of the Framers by selecting the policy which, in its judgment, best effectuates the constitutional aim. This is but a corollary to the grant to Congress of any Article I power. Within the scope established by the Constitution, Congress may set out conditions and tests for patentability. It is the duty of the Commissioner of Patents and of the courts in the administration of the patent system to give effect to the constitutional standard by appropriate application, in each case, of the statutory scheme of the Congress.

Congress quickly responded to the bidding of the Constitution by enacting the Patent Act of 1790 during the second session of the First Congress. It created an agency in the Department of State headed by the Secretary of State, the Secretary of the Department of War and the Attorney General, any two of whom could issue a patent for a period not exceeding 14 years to any petitioner that ‘hath * * * invented or discovered any useful art, manufacture, * * * or device, or any improvement therein not before known or used’ if the board found that ‘the invention or discovery (was) sufficiently useful and important. * * *’ 1 Stat. 110. This group, whose members administered the patent system along with their other public duties, was known by its own designation as ‘Commissioners for the Promotion of Useful Arts.’

Thomas Jefferson, who as Secretary of State was a member of the group, was its moving spirit and might well be called the ‘first administrator of our patent system.’ See Federico 238 (1936). He was not only an administrator of the patent system under the 1790 Act, but was also the author of the 1793 Patent Act. In addition, Jefferson was himself an inventor of great note. His unpatented improvements on plows, to mention but one line of his inventions, won acclaim and recognition on both sides of the Atlantic. Because of his active interest and influence in the early development of the patent system, Jefferson’s views on the general nature of the limited patent monopoly under the Constitution, as well as his conclusions as to conditions for patentability under the statutory scheme, are worthy of note.

Jefferson, like other Americans, had an instinctive aversion to monopolies. It was a monopoly on tea that sparked the Revolution and Jefferson certainly did not favor an equivalent form of monopoly under the new government. His abhorrence of monopoly extended initially to patents as well. From France, he wrote to Madison (July 1788) urging a Bill of Rights provision restricting monopoly, and as against the argument that limited monopoly might serve to incite ‘ingenuity,’ he argued forcefully that ‘the benefit even of limited monopolies is too doubtful to be opposed to that of their general suppression.’

His views ripened, however, and in another letter to Madison (Aug. 1789) after the drafting of the Bill of Rights, Jefferson stated that he would have been pleased by an express provision in this form: ‘Art. 9. Monopolies may be allowed to persons for their own productions in literature, & their own inventions in the arts, for a term not exceeding __ years, but for no longer term & no other purpose.’ And he later wrote: ‘Certainly an inventor ought

to be allowed a right to the benefit of his invention for some certain time. * * * Nobody wishes more than I do that ingenuity should receive a liberal encouragement.’

Jefferson’s philosophy on the nature and purpose of the patent monopoly is expressed in a letter to Isaac McPherson, a portion of which we set out in the margin.² He rejected a natural rights theory in intellectual property rights and clearly recognized the social and economic rationale of the patent system. The patent monopoly was not designed to secure to the inventor his natural right in his discoveries. Rather, it was a reward, an inducement, to bring forth new knowledge. The grant of an exclusive right to an invention was the creation of society—at odds with the inherent free nature of disclosed ideas—and was not to be freely given. Only inventions and discoveries which furthered human knowledge, and were new and useful, justified the special inducement of a limited private monopoly. Jefferson did not believe in granting patents for small details, obvious improvements, or frivolous devices. His writings evidence his insistence upon a high level of patentability.

As a member of the patent board for several years, Jefferson saw clearly the difficulty in ‘drawing a line between the things which are worth to the public the embarrassment of an exclusive patent, and those which are not.’ The board on which he served sought to draw such a line and formulated several rules which are preserved in Jefferson’s correspondence. Despite the board’s efforts, Jefferson saw ‘with what slow progress a system of general rules could be matured.’ Because of the ‘abundance’ of cases and the fact that the investigations occupied ‘more time of the members of the board than they could spare from higher duties, the whole was turned over to the judiciary, to be matured into a system, under which every one might know when his actions were safe and lawful.’ Letter to McPherson. Apparently Congress agreed with Jefferson and the board that the courts should develop additional conditions for patentability. Although the Patent Act was amended, revised or codified some 50 times between 1790 and 1950, Congress steered clear of a statutory set of requirements other than the bare novelty and utility tests reformulated in Jefferson’s draft of the 1793 Patent Act.

III.

The difficulty of formulating conditions for patentability was heightened by the generality of the constitutional grant and the statutes implementing it, together with the underlying policy of the patent system that ‘the things which are worth to the public the embarrassment of an exclusive patent,’ as Jefferson put it, must outweigh the restrictive effect of the limited patent monopoly. The inherent problem was to develop some means of weeding out those inventions which would not be disclosed or devised but for the inducement of a patent.

² “Stable ownership is the gift of social law, and is given late in the progress of society. It would be curious, then, if an idea, the fugitive fermentation of an individual brain, could, of natural right, be claimed in exclusive and stable property. If nature has made anyone thing less susceptible than all others of exclusive property, it is the action of the thinking power called an idea, which an individual may exclusively possess as long as he keeps it to himself; but the moment it is divulged, it forces itself into the possession of everyone, and the receiver cannot dispossess himself of it. Its peculiar character, too, is that no one possesses the less because every other possesses the whole of it. He who receives an idea from me receives instruction himself without lessening mine, as he who lights his taper at mine, receives light without darkening me. That ideas should freely spread from one to another over the globe, for the moral and mutual instruction of man and improvement of his condition, seems to have been peculiarly and benevolently designed by nature when she made them, like fire, expansible over all space, without lessening their density in any point, and, like the air in which we breathe, move, and have our physical being, incapable of confinement or exclusive appropriation. Inventions then cannot, in nature, be a subject of property. Society may give an exclusive right to the profits arising from them, as an encouragement to men to pursue ideas which may produce utility, but this may or may not be done according to the will and convenience of the society, without claim or complaint from anybody.” VI Writings of Thomas Jefferson at 180–181 (Washington ed.).

This Court formulated a general condition of patentability in 1851 in *Hotchkiss v. Greenwood*. The patent involved a mere substitution of materials—porcelain or clay for wood or metal in doorknobs—and the Court condemned it, holding:

‘(U)nless more ingenuity and skill * * * were required * * * than were possessed by an ordinary mechanic acquainted with the business, there was an absence of that degree of skill and ingenuity which constitute essential elements of every invention. In other words, the improvement is the work of the skilful mechanic, not that of the inventor.’

. . . The *Hotchkiss* test laid the cornerstone of the judicial evolution suggested by Jefferson and left to the courts by Congress. The language in the case, and in those which followed, gave birth to ‘invention’ as a word of legal art signifying patentable inventions. . . . The *Hotchkiss* formulation, however, lies not in any label, but in its functional approach to questions of patentability. In practice, *Hotchkiss* has required a comparison between the subject matter of the patent, or patent application, and the background skill of the calling. It has been from this comparison that patentability was in each case determined.

IV.

The 1952 Patent Act.

The Act sets out the conditions of patentability in three sections. An analysis of the structure of these three sections indicates that patentability is dependent upon three explicit conditions: novelty and utility, as articulated and defined in § 101 and § 102, and nonobviousness, the new statutory formulation, as set out in § 103. The first two sections, which trace closely the 1874 codification, express the “new and useful” tests which have always existed in the statutory scheme and, for our purposes here, need no clarification. The pivotal section around which the present controversy centers is § 103. It provides:

“§ 103. Conditions for patentability; non-obvious subject matter” “A patent may not be obtained though the invention is not identically disclosed or described as set forth in section 102 of this title, if the differences between the subject matter sought to be patented and the prior art are such that the subject matter as a whole would have been obvious at the time the invention was made to a person having ordinary skill in the art to which said subject matter pertains. Patentability shall not be negated by the manner in which the invention was made.”

The section is cast in relatively unambiguous terms. Patentability is to depend, in addition to novelty and utility, upon the “non-obvious” nature of the “subject matter sought to be patented” to a person having ordinary skill in the pertinent art.

The first sentence of this section is strongly reminiscent of the language in *Hotchkiss*. Both formulations place emphasis on the pertinent art existing at the time the invention was made, and both are implicitly tied to advances in that art. The major distinction is that Congress has emphasized “nonobviousness” as the operative test of the section, rather than the less definite “invention” language of *Hotchkiss* that Congress thought had led to “a large variety” of expressions in decisions and writings. In the title itself, the Congress used the phrase “Conditions for patentability; *non-obvious subject matter*” (italics added), thus focusing upon “nonobviousness,” rather than “invention.” The Senate and House Reports reflect this emphasis in these terms:

“Section 103, for the first time in our statute, provides a condition which exists in the law and has existed for more than 100 years, but only by reason of decisions of the courts. An invention which has been made, and which is new in the sense that the same thing has not been made before, may still not be patentable if the difference between the new

thing and what was known before is not considered sufficiently great to warrant a patent. That has been expressed in a large variety of ways in decisions of the courts and in writings. Section 103 states this requirement in the title. It refers to the difference between the subject matter sought to be patented and the prior art, meaning what was known before as described in section 102. If this difference is such that the subject matter as a whole would have been obvious at the time to a person skilled in the art, then the subject matter cannot be patented.

That provision paraphrases language which has often been used in decisions of the courts, and the section is added to the statute for uniformity and definiteness. This section should have a stabilizing effect and minimize great departures which have appeared in some cases.”

It is undisputed that this section was, for the first time, a statutory expression of an additional requirement for patentability, originally expressed in *Hotchkiss*. It also seems apparent that Congress intended by the last sentence of § 103 to abolish the test it believed this Court announced in the controversial phrase ‘flash of creative genius,’ used in *Cuno Engineering Corp. v. Automatic Devices Corp.* (1941).

It is contended, however, by some of the parties and by several of the amici that the first sentence of § 103 was intended to sweep away judicial precedents and to lower the level of patentability. Others contend that the Congress intended to codify the essential purpose reflected in existing judicial precedents—the rejection of insignificant variations and innovations of a commonplace sort—and also to focus inquiries under § 103 upon nonobviousness, rather than upon ‘invention,’ as a means of achieving more stability and predictability in determining patentability and validity.

The Reviser’s Note to this section, with apparent reference to *Hotchkiss*, recognizes that judicial requirements as to ‘lack of patentable novelty (have) been followed since at least as early as 1850.’ The note indicates that the section was inserted because it ‘may have some stabilizing effect, and also to serve as a basis for the addition at a later time of some criteria which may be worked out.’ To this same effect are the reports of both Houses, which state that the first sentence of the section ‘paraphrases language which has often been used in decisions of the courts, and the section is added to the statute for uniformity and definiteness.’

We believe that this legislative history, as well as other sources, shows that the revision was not intended by Congress to change the general level of patentable invention. We conclude that the section was intended merely as a codification of judicial precedents embracing the *Hotchkiss* condition, with congressional directions that inquiries into the obviousness of the subject matter sought to be patented are a prerequisite to patentability.

V.

Approached in this light, the § 103 additional condition, when followed realistically, will permit a more practical test of patentability. The emphasis on nonobviousness is one of inquiry, not quality, and, as such, comports with the constitutional strictures.

While the ultimate question of patent validity is one of law, the § 103 condition, which is but one of three conditions, each of which must be satisfied, lends itself to several basic factual inquiries. Under § 103, the scope and content of the prior art are to be determined; differences between the prior art and the claims at issue are to be ascertained; and the level of ordinary skill in the pertinent art resolved. Against this background, the obviousness or nonobviousness of the subject matter is determined. Such secondary considerations as commercial success, long felt but unsolved needs, failure of others, etc., might be utilized to give light to the circumstances surrounding the origin of the subject matter sought to be patented. As indicia of obviousness or nonobviousness, these inquiries may have relevancy.

This is not to say, however, that there will not be difficulties in applying the nonobviousness test. What is obvious is not a question upon which there is likely to be uniformity of thought in every given factual context. The difficulties, however, are comparable to those encountered daily by the courts in such frames of reference as negligence and *scienter*, and should be amenable to a case-by-case development. We believe that strict observance of the requirements laid down here will result in that uniformity and definiteness which Congress called for in the 1952 Act.

While we have focused attention on the appropriate standard to be applied by the courts, it must be remembered that the primary responsibility for sifting out unpatentable material lies in the Patent Office. To await litigation is—for all practical purposes—to debilitate the patent system. We have observed a notorious difference between the standards applied by the Patent Office and by the courts. While many reasons can be adduced to explain the discrepancy, one may well be the free rein often exercised by Examiners in their use of the concept of “invention.” In this connection we note that the Patent Office is confronted with a most difficult task. Almost 100,000 applications for patents are filed each year. Of these, about 50,000 are granted and the backlog now runs well over 200,000. *1965 Annual Report of the Commissioner of Patents*. This is itself a compelling reason for the Commissioner to strictly adhere to the 1952 Act as interpreted here. This would, we believe, not only expedite disposition but bring about a closer concurrence between administrative and judicial precedent.

Although we conclude here that the inquiry which the Patent Office and the courts must make as to patentability must be beamed with greater intensity on the requirements of § 103, it bears repeating that we find no change in the general strictness with which the overall test is to be applied. We have been urged to find in § 103 a relaxed standard, supposedly a congressional reaction to the “increased standard” applied by this Court in its decisions over the last 20 or 30 years. The standard has remained invariable in this Court. Technology, however, has advanced—and with remarkable rapidity in the last 50 years. Moreover, the ambit of applicable art in given fields of science has widened by disciplines unheard of a half century ago. It is but an evenhanded application to require that those persons granted the benefit of a patent monopoly be charged with an awareness of these changed conditions. The same is true of the less technical, but still useful arts. He who seeks to build a better mousetrap today has a long path to tread before reaching the Patent Office. . . .

Questions:

1.) As we saw in Chapter 2, in the context of copyright law the Supreme Court has taken a very deferential approach towards Congress’s interpretation of its powers under the Intellectual Property Clause. *Golan*, for example, appeared to set no limits on Congress’s ability to withdraw material from the public domain and place it back under copyright. In other words, the *Golan* court allowed Congress to do the very thing the *Graham* court says can never be done.

The Congress in the exercise of the patent power may not overreach the restraints imposed by the stated constitutional purpose. Nor may it enlarge the patent monopoly without regard to the innovation, advancement or social benefit gained thereby. **Moreover, Congress may not authorize the issuance of patents whose effects are to remove existing knowledge from the public domain, or to restrict free access to materials already available.**

Is *Graham* still good law, at least in the context of Congress’s ability to make *patent* as

opposed to copyright law? Why might we think the two areas would receive different levels of scrutiny or deference from the courts?

2.) How is the non-obviousness requirement (and for that matter the requirement of novelty) implicated by the bolded sentence above? How does it set boundaries on the statutory definitions of novelty and non-obviousness that Congress may set forth? Without an adequate definition of novelty or non-obviousness, what knowledge could otherwise be withdrawn from the public domain, what access impeded to materials already available? The answer seems relatively clear when it comes to the limits of Congress's powers with respect to *novelty*. If the thing already exists and the public has access to it, then putting it under patent is exactly what *Graham* says Congress cannot authorize and thus, presumably, the courts and the PTO cannot do. But what about *non-obviousness*? What knowledge is being removed from the public domain? What free access to material already available is being restricted? Is the court presuming that the public domain consists not merely of discrete objects of knowledge, but of the *connections* that could be made between those objects by any reasonably skilled practitioner of the art?

3.) Question 2 leads to the question whether the Intellectual Property Clause—as interpreted by *Graham*—requires something *at least as rigorous* as the current standard for non-obviousness. Nearly as rigorous? What are the constitutional limits? Imagine Congress had rewritten § 103 to read

A patent for a claimed invention may not be obtained, notwithstanding that the claimed invention is not identically disclosed as set forth in section 102, unless the inventor thought fairly hard about his work. (The courts should not construe this to require any kind of rocket scientist stuff, but the inventor has to make a mild effort to look beyond the blatantly obvious.) Patentability shall not be negated by the manner in which the invention was made.

Is this constitutional under *Graham*'s standard?

4.) As we will see in a moment, *Graham*'s four part analysis of obviousness is central to the doctrine in this area. Beyond that does *Graham*'s constitutional analysis give courts any guidance about *how* to conduct that inquiry?

1.) A Four Step Test for Obviousness

Graham laid down the basic structure under which analysis of obviousness proceeds to this day.

- 1.) **“The scope and content of the prior art are to be determined.”**
- 2.) **“Differences between the prior art and the claims at issue are to be ascertained”**
- 3.) **“and the level of ordinary skill in the pertinent art resolved.”**
- 4.) **“Such secondary considerations as commercial success, long felt but unsolved needs, failure of others, etc., might be utilized to give light to the circumstances surrounding the origin of the subject matter sought to be patented.”**

Reciprocal Definitions? The alert amongst you will have noticed that some of these inquiries are mutually dependent. How do I know what the scope and content of the prior art

is, unless I know who the PHOSITA is and *vice versa*? If most people working in the field of developing new cryptographic software tools are mathematics PhDs with extensive knowledge of prior cryptographic schemes, then the “scope of the prior art” will include much more than if they are computer scientists who dabble in cryptography. But conversely, the relevant art literally defines the field in which the PHOSITA can be described.

Hindsight Bias? *Graham* describes one danger for patent law—that too lax a standard for inventions will give us a patent system that withdraws material from the public domain and conveys statutory monopolies for mere tinkering. But there is an opposing danger: the psychological literature strongly confirms the existence of a bias that is conventionally referred to as 20/20 hindsight vision. In retrospect, *everything* looks obvious. How do we “de-bias” our decisions about whether an innovation *was* obvious or not?

One answer is the *Graham* structure itself. By formalizing the steps of the analysis, forcing the examiner, or the court, to “show their work,” we might hope that we would avoid hindsight bias. A second answer is provided by the “secondary considerations.” While courts have put varying weights on them, secondary considerations force one to consider the counterfactual. If this was so obvious, and yet everyone in the industry wanted it, why did no one do it before? If it was so obvious, why did others fail repeatedly? If it was so obvious—to use another secondary consideration not mentioned here—why is it that many firms are willing to *license* the technology, apparently in the belief the patent is sound?

The rest of the chapter proceeds as follows. We will start with a case that goes through all of the *Graham* steps *en route* to a decision on obviousness. Then we will turn to a few instructive cases fleshing out some of the individual steps of the *Graham* inquiry. What is the scope and content of the prior art? Who bears the burden of proof on obviousness? Is an invention obvious if there are thousands of possible solutions to a problem and the PHOSITA would know to try them, one after another? How do we define the PHOSITA?

Note: In *KSR v. Teleflex* (2007), the Supreme Court affirmed the *Graham v. Deere* framework for assessing obviousness and endorsed an “expansive and flexible” approach to the inquiry, rejecting the Federal Circuit’s overly “rigid” application of its “‘teaching, suggestion, or motivation’ (TSM) test, under which a patent claim is only proved obvious if the prior art, the problem’s nature, or the knowledge of a person having ordinary skill in the art reveals some motivation or suggestion to combine the prior art teachings.”

Stratoflex, Inc. v. Aeroquip Corp.
713 F.2d 1530 (Fed. Cir. 1983)



MARKEY, Chief Judge.

II. Background
A. The Technology

Stratoflex and Aeroquip manufacture electrically conductive polytetrafluoroethylene (PTFE) [also referred to as “Teflon”] tubing used in the aircraft and missile industry to convey pressurized fuel, lubricants, and other fluids.

PTFE has replaced organic and synthetic rubbers and plastic in fuel hoses because it has a number of superior characteristics. Though pure PTFE is dielectric (non-conductive), it can be made with fillers to make it conductive, though the “filled” tubing is more susceptible to leakage when voids form between the PTFE and filler particles.

B. The Invention

The Slade invention relates to a composite PTFE tubing, formed of an inner layer of electrically conductive PTFE having particles such as carbon black uniformly distributed in it and an outer layer of essentially pure non-conductive PTFE. Claims 1 and 7 are representative:

1. A tubular extrudate formed of attached concentric tubular extrusions, the inner tubular extrusion comprising associated particles of unsintered tetrafluoroethylene polymer and pulverulent, inert, electrically conductive particles, and the outer tubular extrusion comprising associated particles of unsintered tetrafluoroethylene polymer.
7. A tube of polytetrafluoroethylene and the like for conducting fluids under pressure and including means for discharge of internal static electricity to the ends of the tube and grounding the same from the tube interior at said ends in order to maintain the polytetrafluoroethylene tubing performance characteristics, said tubing having an integral polytetrafluoroethylene wall structure with an interior liner portion of a substantially annular conformation from end to end and having a uniform dispersion of electrically conductive particles embedded therein, the major portion of said tubing wall completely surrounding said liner portion exteriorly and being relatively nonconductive in character, said surrounding portion together with said liner containing fluid under pressures uniformly within said tubing. . . .

The particles in the inner layer of the claimed tubing dissipate electrostatic charges built up on the inner surface of the tubing, conducting them lengthwise of the tubing to grounded metal fittings at the ends of a hose assembly of which the tubing is part, to prevent arcing or discharging through the tubing wall to the surrounding metal braid. Arcing causes “pin holes” through which fuel can leak. The outer layer is coextruded or bonded around the inner layer to contain any fuel leaking through the inner layer. The composite tubing has excellent conductivity, while retaining the desirable characteristics of PTFE tubing.

C. Events Leading to the '087 Patent

Pure PTFE tubing had been used successfully in aircraft engines since at least 1956. In 1959, with the introduction of hydrocarbon jet fuels, leaks were noticed. Aeroquip assigned two staff engineers, Abbey and Upham, to determine the cause. They found the problem to be the arcing of electrostatic charges through the wall of the pure dielectric PTFE tubing to create “pin holes” as described above.

Abbey and Upham found the “pin hole” phenomenon exhibited by all three types of PTFE (White-Titeflex; Pink/Red-Aeroquip; Black-Goodrich) used in aircraft engines. The black tubing appeared superior because the carbon black it contained gave it an intermittent conductivity. The carbon black took the form of discontinuous strings and arcing across the spaces between string ends conveyed charges to the ends of the tubing. Electrical erosion of the strings, however, widened the spaces, destroying conductivity and leading to the “pin hole” phenomenon. Abbey and Upham concluded that susceptibility of PTFE tubing to “pin holing” was proportional to its conductivity, and that carbon black increased the conductivity of PTFE tubing.

In early 1960, having determined the cause of leaking, Aeroquip approached Raybestos-Manhattan (Raybestos), a PTFE hose manufacturer, for a solution. Aeroquip later purchased the hose section of Raybestos, obtaining the Slade patent by mesne assignment.

Raybestos assigned the project to the inventor, Winton Slade, who prepared several

samples of conductive PTFE tubing (powdered lead, copper, chemically etched, and carbon black) and sent them for testing to Aeroquip in the summer of 1960. In the Fall, Aeroquip ordered a small production quantity of carbon black tubing. That tubing was not a composite and the carbon black was not uniformly distributed in it.

Slade conceived of the composite tube of the invention as early as August 5, 1960 and reduced it to practice in November of 1961. He filed a patent application on May 22, 1962, with claims directed to the composite tubing and also to various processes for making it. . . .

. . . Slade's original application issued with its product claims as the '087 patent on October 1, 1969.

D. Stratoflex Actions

From 1962 to 1970, Stratoflex purchased PTFE tubing containing carbon black from B.F. Goodrich. When Goodrich ceased production, Stratoflex purchased conductive PTFE tubing made by Titeflex under its license. Stratoflex then began manufacturing and selling its own "124" and "127" composite tubing having an inner layer with conductive carbon black uniformly dispersed throughout, and an outer layer that is essentially non-conductive, though that outer layer includes a small amount of carbon black to color the tubing and to aid extrusion.

On December 8, 1978, Aeroquip charged that Stratoflex's unauthorized manufacture and sale of "124" and "127" tubing infringed its rights under the '087 patent.

E. Trial and Opinion

Trial was held on December 15, 16, 18, 19 and 22, 1980. Stratoflex alleged that the '087 patent was invalid as anticipated under 35 U.S.C. § 102, as having been in public use or on sale, 35 U.S.C. § 102(b); for obviousness, 35 U.S.C. § 103; or because the claims were indefinite, 35 U.S.C. § 112. Judge Boyle* decided the validity issue on 35 U.S.C. § 103, and the appeal concerns only that Section.

I. VALIDITY

. . . (B) Obviousness

The declaration that claims 1, 3, 4, 6, and 7 of the '087 patent are invalid was based on a conclusion that the inventions set forth in those claims would have been obvious under 35 U.S.C. § 103, in the light of facts found in the course of following the guidelines set forth in *Graham v. John Deere Co.* (1966). Aeroquip contends that error occurred in findings on the scope and content of the prior art, level of ordinary skill, and differences between the prior art and the claimed invention, and in the legal conclusion of obviousness based on those findings.

Scope and Content of the Prior Art

Aeroquip contends that the scope of the relevant prior art excludes rubber hose because PTFE is a unique material, possessing properties that differ significantly from rubber, and that, because the claims are limited to PTFE, the rubber hose art could at most be peripherally relevant as background information.

The scope of the prior art has been defined as that "reasonably pertinent to the particular problem with which the inventor was involved." *In re Wood* (Cust. & Pat. App. 1979). The problem confronting Slade was preventing electrostatic buildup in PTFE

* [Casebook Editors' comment: No relation.]

tubing caused by hydrocarbon fuel flow while precluding leakage of fuel. None of the unique properties of PTFE would change the nature of that problem. Nor would anything of record indicate that one skilled in the art would not include the rubber hose art in his search for a solution to that problem.

Indeed, Slade himself referred to a standard textbook on conductive carbon black in rubber when he began his search for a solution. Judge Boyle correctly found Slade's act an acknowledgement by the problem solver of what he considered relevant prior art.

The examiner cited two prior art references in the rubber hose art, one disclosing the problem of electrostatic buildup caused by fuel flow. The Abbey-Upham report, though concerned with PTFE, included a conductivity comparison with carbon black filled rubber hose, and its bibliography listed several articles on electrostatic buildup in rubber. The record reflects that PTFE and rubber are used by the same hose manufacturers to make hoses and that the same and similar problems have been experienced with both. There is no basis for finding that a solution found for a problem experienced with one material would not be looked to when facing a problem with the other. The finding that the rubber hose art is relevant and thus within the scope of the art was not clearly erroneous.

The content of the prior art included the Abbey-Upham Report and several patents relating to conductive and composite rubber hose and to PTFE tubing.

The Abbey-Upham Report, as above indicated, discloses the cause of PTFE tubing "pin holes" as the arcing of electrostatic charges laterally through the non-conductive PTFE tubing wall to the surrounding metal braid, that carbon black increases conductivity of PTFE, and that susceptibility of PTFE tubing to "pinholing" is directly proportional to its conductivity. Judge Boyle correctly found the report to have disclosed the basic concepts underlying the claimed invention, but not that of forming PTFE tubing as a composite having a conductive inner layer and a nonconductive outer layer.

United States Patent No. 2,341,360 ('360 patent) teaches composite tubing having carbon black in one layer to make it electrically conductive for dissipation of static electricity.

U.S. Patent No. 2,632,205 ('205 patent) teaches a rubber or plastic composite tubing for conveying fluids and having powdered metal or other conductive materials embedded along the inner wall to conduct electric charges lengthwise of the tubing.

U.S. Patent No. 3,070,132 teaches extrusion of carbon black mixed with plastic to form a continuous conductive stripe in a normally dielectric tubing to prevent accumulation of electrostatic charges. It teaches that electrostatic discharge causes leaks through the wall of the tubing and explosions when inflammable materials are conveyed. It mentions rubber tubing.

U.S. Patent No. 2,108,759 discloses an "antistatic" fuel nozzle. It teaches dissipation of electrostatic charges caused by hydrocarbon fuel flow, before those charges can arc, by employing conductive materials like synthetic rubber in an inner layer of the nozzle.

U.S. Patent No. 2,781,288 ('288 patent) teaches a composite rubber hose with each layer arranged to take advantage of its particular properties. It suggests carbon black as a filler, but not as a conductor.

U.S. Patent No. 2,645,249 ('249 patent) and U.S. Patent No. 2,501,690 ('690 patent) teach composite tubing with each layer containing different fillers to impart varying characteristics to the inner and outer layers.

U.S. Patent No. 2,863,174, U.S. Patent No. 2,685,707, and U.S. Patent No. 2,752,637 disclose the use of carbon black as an extrusion aid in forming PTFE.

U.S. Patent No. 2,945,265 ('265 patent) teaches coextrusion of PTFE with different fillers, carbon black being used as a coloring agent.

Aeroquip's attack on the content-of-the-prior-art findings is limited to its argument that rubber hose should be excluded. That argument having been found wanting, the findings on the content of the prior art cannot be viewed as clearly erroneous.

Consideration of the scope and content of the prior art tilts the scales of decision toward a conclusion of obviousness. Thus the Abbey-Upham report teaches use of carbon black to increase conductivity of PTFE tubing to reduce the chance of electrostatic buildup on the tubing wall. It would appear to have been obvious to one skilled in the art to place the conductive material in the wall where the electrostatic buildup occurs (here the inner wall subjected to electrostatic buildup by fuel flow) as suggested by the '360 and '205 patents. It would appear to have been obvious from the '288, '249, and '690 patents to form a composite tubing with layers arranged to take advantage of their physical and chemical properties. On this record, consideration of the prior art as a whole, and in the absence of evidence that any special problem in following its teachings was created by the unique properties of PTFE, it would appear to have been obvious to place a conductive PTFE layer inside an essentially non-conductive outer PTFE layer to prevent fuel seepage associated with the conductive layer.

Differences Between the Claimed Invention and the Prior Art

. . . Aeroquip concedes that pure PTFE had been known to be dielectric, that carbon black was known to be conductive, and that PTFE had been made into tubing containing at least a small amount of carbon black. It alleges that the prior art does not show the composite tubing set forth in the claims, specifically a composite PTFE tubing with its inner layer formed of uniformly distributed carbon black and PTFE, to provide conductivity sufficient to dissipate electrostatic buildup, and an outer layer of relatively pure PTFE that prevents fuel leakage. It is true that no single reference shows all elements of the claims, but the holding here is one of invalidity for obviousness, not for anticipation. The question, therefore, is whether the inventions set forth in claims 1, 3, 4, 6 and 7, each as a whole, would have been obvious to one of ordinary skill in the art when they were made, in view of the teachings of the prior art as a whole.

Though findings on the "differences" from the prior art are suggested by *Graham v. John Deere*, the question under 35 U.S.C. § 103 is not whether the differences *themselves* would have been obvious. Consideration of differences, like each of the findings set forth in *Graham*, is but an aid in reaching the ultimate determination of whether the claimed invention *as a whole* would have been obvious.

Judge Boyle found that the differences between the claimed invention and the prior art were use of *PTFE* in concentric tubes and the "salt and pepper" process of forming the inner layer. The first difference would indicate a mere change of material. The second difference is, of course, irrelevant as stated, the claimed inventions having nothing to do with the process of making the inner layer. The finding may have been meant to indicate that the second difference lay in the structural *result* of the "salt and pepper" process, namely a uniform dispersion of carbon black particles in the inner layer (a limitation appearing only in claim 7).

With respect to use of a different material, the problem (leakage) and the cause ("pin holes" from electrostatic charges) were known with respect to that material (PTFE). A solution for the electrostatic charge problems, i.e., dissipation of charges lengthwise of the tubing, was known. Nothing in the first difference found would indicate that it would have been nonobvious to transfer that solution from tubing formed of other materials to tubing formed of PTFE. As above indicated, no special problem needed to be or was overcome in substituting a different material (PTFE) for the materials (rubber and plastics) of the prior art.

Similarly, with respect to uniform dispersion of conductive particles, it was known that spaces between carbon black areas in tubing permit arcing. Nothing of record establishes that use of uniform dispersion to limit or eliminate such spaces would not have been obvious. The same is true respecting use of a nonconductive outer layer to contain leakage from the inner conductive layer.

Aeroquip challenges the finding that the Abbey-Upham report does not teach away from use of carbon black in PTFE tubing, citing this language in the report: “The possibility of establishing continuous longitudinal strings of carbon particles during extrusion, especially in view of the relatively small percentage of carbon black used in Teflon hose seemed remote.” . . .

In the sentence following that cited to us by Aeroquip, the Abbey-Upham report describes uneven spacing between carbon black particles as a possible cause of intermittent conductivity. Far from “teaching away,” therefore, the report may be viewed as pointing in the direction of uniform dispersion of such particles, as set forth in claim 7, to produce less intermittent conductivity.

The findings that the differences here were use of a different material and uniform dispersion of carbon black particles were not clearly erroneous. Those differences do not tilt the scales toward a conclusion of nonobviousness of the invention as a whole in light of all prior art teachings summarized above.

Level of Ordinary Skill

The district court found the level of ordinary skill to be that of a chemical engineer or equivalent, having substantial experience in the extrusion arts. Aeroquip says that was too high, suggesting that of an engineer or technician in the PTFE art, as described by its expert, Townsend Beaman. The suggestion is but another effort to limit the prior art to PTFE tubing and avoid inclusion of the art of making fuel hoses of other materials.

The level of ordinary skill may be determined from several factors. Slade had the level of skill set by the district court. Stratoflex witness Linger was a mechanical engineer with years of experience in the rubber and PTFE hose art. Mr. Beaman was patent counsel for Aeroquip. Judge Boyle correctly viewed Beaman as an observer of, not a worker in, the relevant art.

The statute, 35 U.S.C. § 103, requires that a claim be declared invalid only when the invention set forth in that claim can be said to have been obvious “to one of *ordinary* skill in the art.” (Emphasis added.) As an aid in determining obviousness, that requirement precludes consideration of whether the invention would have been obvious (as a whole and just before it was made) to the rare genius in the art, or to a judge or other layman after learning all about the invention.

Aeroquip has not shown the finding on the level of ordinary skill in the art to have been erroneous here.

Secondary Considerations

It is jurisprudentially inappropriate to disregard any relevant evidence on any issue in any case, patent cases included. Thus evidence rising out of the so-called “secondary considerations” must always when present be considered en route to a determination of obviousness. Indeed, evidence of secondary considerations may often be the most probative and cogent evidence in the record. It may often establish that an invention appearing to have been obvious in light of the prior art was not. It is to be considered as part of all the evidence, not just when the decisionmaker remains in doubt after reviewing the art.

Judge Boyle made findings on secondary considerations, but said she did not include them in her analysis because she believed the claimed inventions were plainly

obvious and “those matters without invention will not make patentability” and should be considered only in a close case. That was error. . . .

A nexus is required between the merits of the claimed invention and the evidence offered, if that evidence is to be given substantial weight enroute to conclusion on the obviousness issue.

Aeroquip says commercial success is shown because: the “entire industry” makes the tubing claimed in the ’087 patent; only Stratoflex is not licensed under the ’087 patent; Curtiss-Wright retrofitted 10,000 engines with conductive tubing; and military specifications for conductive tubing are met only by tubing claimed in the ’087 patent. We are not persuaded.

Recognition and acceptance of the patent by competitors who take licenses under it to avail themselves of the merits of the invention is evidence of nonobviousness. Here, however, Aeroquip does not delineate the make-up of the “entire industry.” The record reflects only two manufacturers, Titeflex and Resistoflex, in addition to the parties. Titeflex has a royalty-free license, resulting from the interference settling agreement described above. Resistoflex has a license that includes several other patents and the right to use the trademark “HI-PAC” for complete hose assemblies. Aeroquip has shown neither a nexus between the merits of the invention and the licenses of record, nor that those licenses arose out of recognition and acceptance of the patent.

No evidence of record establishes that tubing covered by the claims of the ’087 patent was used in the Curtiss-Wright retrofit. It cannot therefore be given weight in respect of commercial success.

The military specifications were promulgated after the claimed invention was known. Thus the invention did not meet a long-felt but unfilled need expressed in the specifications. Moreover, the record does not support Aeroquip’s assertion that the specifications can be met only by tubing covered by the claims of the ’087 patent. The nexus required to establish commercial success is therefore not present with respect to the military specifications.

Nor is there evidence that others skilled in the art tried and failed to find a solution for the problem. Aeroquip cites Abbey and Upham, but their effort was limited to investigation of the problem and its cause, and was not directed to its solution.

Upon full consideration of the evidence respecting the secondary considerations in this case, and of Aeroquip’s arguments, we are persuaded that nonobviousness is not established by that evidence. Judge Boyle’s error in refusing to include that evidence in her analysis was therefore in this case harmless.

“Synergism” and “Combination Patents”

Judge Boyle said “synergism” is “a symbolic reminder of what constitutes nonobviousness when a combination patent is at issue,” and that under “either standard (*Graham* analysis or synergism) the combination . . . simply lacks the unique essence of authentic contribution to the Teflon art which is the heart of invention.”

A requirement for “synergism” or a “synergistic effect” is nowhere found in the statute, 35 U.S.C. When present, for example in a chemical case, synergism may point toward nonobviousness, but its absence has no place in evaluating the evidence on obviousness. The more objective findings suggested in *Graham*, are drawn from the language of the statute and are fully adequate guides for evaluating the evidence relating to compliance with 35 U.S.C. § 103. Judge Boyle treated synergism as an alternative consideration. Hence the error of its analytical inclusion is harmless in view of Judge Boyle’s employment of the *Graham* aids.

The reference to a “combination patent” is equally without support in the statute.

There is no warrant for judicial classification of patents, whether into “combination” patents and some other unnamed and undefined class or otherwise. Nor is there warrant for differing treatment or consideration of patents based on a judicially devised label. Reference to “combination” patents is, moreover, meaningless. Virtually *all* patents are “combination patents,” if by that label one intends to describe patents having claims to inventions formed of a combination of elements. It is difficult to visualize, at least in the mechanical-structural arts, a “non-combination” invention, i.e., an invention consisting of a *single* element. Such inventions, if they exist, are rare indeed. Again, however, Judge Boyle’s inclusion in her analysis of a reference to the ’087 patent as a “combination” patent was harmless in view of her application of *Graham* guidelines.

Similarly, Judge Boyle’s reference to “the heart of invention” was here a harmless fall-back to the fruitless search for an inherently amorphous concept that was rendered unnecessary by the statute, 35 U.S.C. The *Graham* analysis here applied properly looked to *patentability*, not to “invention.”

We sit to review judgments, not opinions. The analysis reflected in an opinion filed with the judgment appealed from may on occasion be so flawed, however, as to obfuscate the true basis for the judgment or to establish that the judgment was erroneously based. Such might have here been the case if the judgment had not been accompanied by the alternative and proper analysis under *Graham* described above. In light of that alternative analysis, in which we see no error, we affirm the judgment declaring claims 1, 3, 4, 6, and 7 invalid for obviousness.

Questions:

1.) How would you draft the opinion to come out the other way? In other words, how would you characterize the facts on each of the factors the court discusses in order to find that the invention was non-obvious and thus patentable?

2.) Ordinary skill in the art:

The district court found the level of ordinary skill to be that of a chemical engineer or equivalent, having substantial experience in the extrusion arts. Aeroquip says that was too high. . . . The statute, 35 U.S.C. § 103, requires that a claim be declared invalid only when the invention set forth in that claim can be said to have been obvious “to one of *ordinary* skill in the art.” As an aid in determining obviousness, that requirement precludes consideration of whether the invention would have been obvious (as a whole and just before it was made) to the rare genius in the art, or to a judge or other layman after learning all about the invention.

How does one determine what “the art” is or what “ordinary skill” is? This is not a rhetorical question. What factual information would you look to? The level of education and experience typical in someone assigned to this task by a competitor? The qualifications that firms typically look for in hiring decisions? The qualifications of inventors who have made similar inventions? The person you think would be acceptable for such a task? (Also, “substantial experience in the extrusion arts”? Nice.)

3.) What was your gut feeling on this case as you read it? How did you think it was going to come out? If your prediction differed from the actual result, why the difference—either in your view or the court’s?

4.) “Teaching Away:” Prior art references do not always render a new innovation more obvious. They may make it less obvious by “teaching away” from the solution found—

suggesting implicitly that this is the wrong line of development to pursue. Why does the court reject “teaching away” in this case?

2.) The Scope of Prior Art

In re Carl D. Clay
966 F.2d 656 (Fed. Cir. 1992)



LOURIE, Circuit Judge.

Carl D. Clay appeals the decision of the United States Patent and Trademark Office, Board of Patent Appeals and Interferences, affirming the rejection of claims 1–11 and 13 as being unpatentable under 35 U.S.C. § 103. These are all the remaining claims in application Serial No. 245,083, filed April 28, 1987, entitled “Storage of a Refined Liquid Hydrocarbon Product.” We reverse.

BACKGROUND

Clay’s invention, assigned to Marathon Oil Company, is a process for storing refined liquid hydrocarbon product in a storage tank having a dead volume between the tank bottom and its outlet port. The process involves preparing a gelation solution which gels after it is placed in the tank’s dead volume; the gel can easily be removed by adding to the tank a gel-degrading agent such as hydrogen peroxide. Claims 1, 8, and 11 are illustrative of the claims on appeal:

1. A process for storing a refined liquid hydrocarbon product in a storage tank having a dead volume between the bottom of said tank and an outlet port in said tank, said process comprising:

- preparing a gelation solution comprising an aqueous liquid solvent, an acrylamide polymer and a crosslinking agent containing a polyvalent metal cation selected from the group consisting of aluminum, chromium and mixtures thereof, said gelation solution capable of forming a rigid crosslinked polymer gel which is substantially insoluble and inert in said refined liquid hydrocarbon product;
- placing said solution in said dead volume;
- gelling said solution substantially to completion in said dead volume to produce said rigid gel which substantially fills said dead volume; and
- storing said refined liquid hydrocarbon product in said storage tank in contact with said gel without substantially contaminating said product with said gel and without substantially degrading said gel.

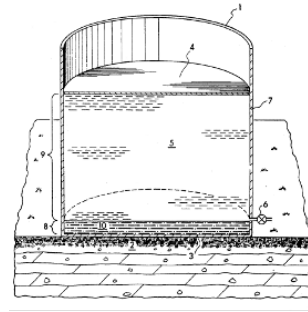

Image from Clay’s patent

8. The process of claim 1 further comprising removing said rigid gel from said dead volume by contacting said gel with a chemical agent which substantially degrades said gel to a flowing solution.

11. The process of claim 1 wherein said gelation solution further comprises an aqueous liquid contaminant present in said dead volume which dissolves in said solution when said solution is placed in said dead volume.

Two prior art references were applied against the claims on appeal. They were U.S. Patent 4,664,294 (Hetherington), which discloses an apparatus for displacing dead space liquid using impervious bladders, or large bags, formed with flexible membranes; and U.S. Patent 4,683,949 (Sydansk), also assigned to Clay's assignee, Marathon Oil Company, which discloses a process for reducing the permeability of hydrocarbon-bearing formations and thus improving oil production, using a gel similar to that in Clay's invention.

The Board agreed with the examiner that, although neither reference alone describes Clay's invention, Hetherington and Sydansk combined support a conclusion of obviousness. It held that one skilled in the art would glean from Hetherington that Clay's invention "was appreciated in the prior art and solutions to that problem generally involved filling the dead space with *something*."

The Board also held that Sydansk would have provided one skilled in the art with information that a gelation system would have been impervious to hydrocarbons once the system gelled. The Board combined the references, finding that the "cavities" filled by Sydansk are sufficiently similar to the "volume or void space" being filled by Hetherington for one of ordinary skill to have recognized the applicability of the gel to Hetherington.

DISCUSSION

The issue presented in this appeal is whether the Board's conclusion was correct that Clay's invention would have been obvious from the combined teachings of Hetherington and Sydansk. Although this conclusion is one of law, such determinations are made against a background of several factual inquiries, one of which is the scope and content of the prior art. *Graham v. John Deere Co.* (1966).

A prerequisite to making this finding is determining what is "prior art," in order to consider whether "the differences between the subject matter sought to be patented and the prior art are such that the subject matter as a whole would have been obvious at the time the invention was made to a person having ordinary skill in the art." 35 U.S.C. § 103. Although § 103 does not, by its terms, define the "art to which [the] subject matter [sought to be patented] pertains," this determination is frequently couched in terms of whether the art is analogous or not, i.e., whether the art is "too remote to be treated as prior art." *In re Sovish* (Fed. Cir. 1985).

Clay argues that the claims at issue were improperly rejected over Hetherington and Sydansk, because Sydansk is nonanalogous art. Whether a reference in the prior art is "analogous" is a fact question. Thus, we review the Board's decision on this point under the clearly erroneous standard.

Two criteria have evolved for determining whether prior art is analogous: (1) whether the art is from the same field of endeavor, regardless of the problem addressed, and (2) if the reference is not within the field of the inventor's endeavor, whether the reference still is reasonably pertinent to the particular problem with which the inventor is involved.

The Board found Sydansk to be within the field of Clay's endeavor because, as the Examiner stated, "one of ordinary skill in the art would certainly glean from [Sydansk] that the rigid gel as taught therein would have a number of applications within the manipulation of the storage and processing of hydrocarbon liquids . . . [and that] the gel as taught in Sydansk would be expected to function in a similar manner as the bladders in the Hetherington patent." These findings are clearly erroneous.

The PTO argues that Sydansk and Clay's inventions are part of a common endeavor—

“maximizing withdrawal of petroleum stored in petroleum reservoirs.” However, Sydansk cannot be considered to be within Clay’s field of endeavor merely because both relate to the petroleum industry. Sydansk teaches the use of a gel in unconfined and irregular volumes within generally underground natural oil-bearing formations to channel flow in a desired direction; Clay teaches the introduction of gel to the confined dead volume of a man-made storage tank. The Sydansk process operates in extreme conditions, with petroleum formation temperatures as high as 115°C and at significant well bore pressures; Clay’s process apparently operates at ambient temperature and atmospheric pressure. Clay’s field of endeavor is the storage of refined liquid hydrocarbons. The field of endeavor of Sydansk’s invention, on the other hand, is the extraction of crude petroleum. The Board clearly erred in considering Sydansk to be within the same field of endeavor as Clay’s.

Even though the art disclosed in Sydansk is not within Clay’s field of endeavor, the reference may still properly be combined with Hetherington if it is reasonably pertinent to the problem Clay attempts to solve. A reference is reasonably pertinent if, even though it may be in a different field from that of the inventor’s endeavor, it is one which, because of the matter with which it deals, logically would have commended itself to an inventor’s attention in considering his problem. Thus, the purposes of both the invention and the prior art are important in determining whether the reference is reasonably pertinent to the problem the invention attempts to solve. If a reference disclosure has the same purpose as the claimed invention, the reference relates to the same problem, and that fact supports use of that reference in an obviousness rejection. An inventor may well have been motivated to consider the reference when making his invention. If it is directed to a different purpose, the inventor would accordingly have had less motivation or occasion to consider it.

Sydansk’s gel treatment of underground formations functions to fill anomalies so as to improve flow profiles and sweep efficiencies of injection and production fluids through a formation, while Clay’s gel functions to displace liquid product from the dead volume of a storage tank. Sydansk is concerned with plugging formation anomalies so that fluid is subsequently diverted by the gel into the formation matrix, thereby forcing bypassed oil contained in the matrix toward a production well. Sydansk is faced with the problem of recovering oil from rock, i.e., from a matrix which is porous, permeable sedimentary rock of a subterranean formation where water has channeled through formation anomalies and bypassed oil present in the matrix. Such a problem is not reasonably pertinent to the particular problem with which Clay was involved—preventing loss of stored product to tank dead volume while preventing contamination of such product. Moreover, the subterranean formation of Sydansk is not structurally similar to, does not operate under the same temperature and pressure as, and does not function like Clay’s storage tanks. See *In re Ellis* (CCPA 1973) (“the similarities and differences in structure and function of the invention disclosed in the references . . . carry far greater weight [in determining analogy]”).

A person having ordinary skill in the art would not reasonably have expected to solve the problem of dead volume in tanks for storing refined petroleum by considering a reference dealing with plugging underground formation anomalies. The Board’s finding to the contrary is clearly erroneous. Since Sydansk is non-analogous art, the rejection over Hetherington in view of Sydansk cannot be sustained.

CONCLUSION

For the foregoing reasons, the decision of the Board is
REVERSED.

Questions:

- 1.) Why does the court find this non-analogous prior art? What are the key differences on which it focuses? Are those absolute (that is, depending on differences in physical phenomena such as temperature and pressure) or relative to a particular specialty and the typical learning of that specialty? Both?
- 2.) When may references that are outside the PHOSITA's "field of endeavor" nevertheless be relevant for the purposes of obviousness?

3.) Burden of Proof and "Obvious to Try"*In re Bell*

991 F.2d 781 (Fed. Cir. 1993)



LOURIE, Circuit Judge.

Applicants Graeme I. Bell, Leslie B. Rall, and James P. Merryweather (Bell) appeal from the March 10, 1992 decision of the U.S. Patent and Trademark Office (PTO) Board of Patent Appeals and Interferences, Appeal No. 91-1124, affirming the examiner's final rejection of claims 25-46 of application Serial No. 065,673, entitled "Preproinsulin-Like Growth Factors I and II," as unpatentable on the ground of obviousness under 35 U.S.C. § 103 (1988). Because the Board erred in concluding that the claimed nucleic acid molecules would have been obvious in light of the cited prior art, we reverse.

BACKGROUND

The claims of the application at issue are directed to nucleic acid molecules (DNA and RNA) containing human sequences which code for human insulin-like growth factors I and II (IGF), single chain serum proteins that play a role in the mediation of somatic cell growth following the administration of growth hormones.

The relevant prior art consists of two publications by Rinderknecht disclosing amino acid sequences for IGF-I and -II and U.S. Patent 4,394,443 to Weissman et al., entitled "Method for Cloning Genes." Weissman describes a general method for isolating a gene for which at least a short amino acid sequence of the encoded protein is known. The method involves preparing a nucleotide probe corresponding to the known amino acid sequence and using that probe to isolate the gene of interest. It teaches that it is advantageous to design a probe based on amino acids specified by unique codons. The Weissman patent specifically describes the isolation of a gene which codes for human histocompatibility antigen, a protein unrelated to IGF. It describes the design of the probe employed, stating that it was based on amino acids specified by unique codons.

The examiner rejected the claims as obvious over the combined teachings of Rinderknecht and Weissman. She determined that it would have been obvious, "albeit tedious," from the teachings of Weissman to prepare probes based on the Rinderknecht amino acid sequences to obtain the claimed nucleic acid molecules. According to the examiner, "it is clear from [Weissman] that the ordinary artisan knows how to find the nucleic acid when the amino acid sequence is known" and that "the claimed sequences and hosts would have been readily determinable by and obvious to those of ordinary skill

in the art at the time the invention was made.”

The Board affirmed the examiner’s rejection, holding that the examiner had established a prima facie case of obviousness for the claimed sequences “despite the lack of conventional indicia of obviousness, e.g., structural similarity between the DNA which codes for IGF-I and the amino acid sequence of the polypeptide which constitutes [*sic*] IGF-I.” The Board reasoned that “although a protein and its DNA are not structurally similar, they are correspondently linked via the genetic code.” In view of Weissman, the Board concluded that there was no evidence “that one skilled in the art, knowing the amino acid sequences of the desired proteins, would not have been able to predictably clone the desired DNA sequences without undue experimentation.”

The issue before us is whether the Board correctly determined that the amino acid sequence of a protein in conjunction with a reference indicating a general method of cloning renders the gene prima facie obvious.

DISCUSSION

We review an obviousness determination by the Board *de novo*. Bell argues that the PTO has not shown how the prior art references, either alone or in combination, teach or suggest the claimed invention, and thus that it has failed to establish a prima facie case of obviousness.

We agree. The PTO bears the burden of establishing a case of prima facie obviousness. “A prima facie case of obviousness is established when the teachings from the prior art itself would appear to have suggested the claimed subject matter to a person of ordinary skill in the art.” *In re Rinehart* (CCPA 1976).

The Board supported the examiner’s view that the “correspondent link” between a gene and its encoded protein via the genetic code renders the gene obvious when the amino acid sequence is known. In effect, this amounts to a rejection based on the Rinderknecht references alone. Implicit in that conclusion is the proposition that, just as closely related homologs, analogs, and isomers in chemistry may create a prima facie case, see *In re Dillon* (Fed. Cir. 1990) (en banc), *cert. denied*, 111 S. Ct. 1682, (1991), the established relationship in the genetic code between a nucleic acid and the protein it encodes also makes a gene prima facie obvious over its correspondent protein.

We do not accept this proposition. It may be true that, knowing the structure of the protein, one can use the genetic code to hypothesize possible structures for the corresponding gene and that one thus has the potential for obtaining that gene. However, because of the degeneracy of the genetic code, there are a vast number of nucleotide sequences that might code for a specific protein. In the case of IGF, Bell has argued without contradiction that the Rinderknecht amino acid sequences could be coded for by more than 10^{36} different nucleotide sequences, only a few of which are the human sequences that Bell now claims.³ Therefore, given the nearly infinite number of possibilities suggested by the

³ [Casebook Editor’s Note: Many sources, and at least two prominent casebooks, print this number as “1036.” Readers of the actual case will see that it is in fact 10^{36} —10 followed by 35 zeroes. For magnitude comparison, the distance from our house to Houston is a little over 1036 miles. The distance to the sun in miles is a little less than 10 followed by 7 zeroes. (28 more zeroes to go.) It’s the difference between going to Houston and getting a frequent flier account to the stars. The magnitude of the number seemed to be very important to the Federal Circuit. Whether the CAFC is *right* that that is the relevant number is a separate question. Many biologists would say the CAFC was wrong, that they based their assessment of the obviousness of biotech procedures on an outdated perception of arcane difficulty in what was routine, if tedious bench work. Nevertheless, knowing what magnitude of task they *thought* the inventors were facing here is important.]

prior art, and the failure of the cited prior art to suggest which of those possibilities is the human sequence, the claimed sequences would not have been obvious.

Bell does not claim all of the 10^{36} nucleic acids that might potentially code for IGF. Neither does Bell claim all nucleic acids coding for a protein having the biological activity of IGF. Rather, Bell claims only the human nucleic acid sequences coding for IGF. Absent anything in the cited prior art suggesting which of the 10^{36} possible sequences suggested by Rinderknecht corresponds to the IGF gene, the PTO has not met its burden of establishing that the prior art would have suggested the claimed sequences.

This is not to say that a gene is never rendered obvious when the amino acid sequence of its coded protein is known. Bell concedes that in a case in which a known amino acid sequence is specified exclusively by unique codons, the gene might have been obvious. Such a case is not before us. Here, where Rinderknecht suggests a vast number of possible nucleic acid sequences, we conclude that the claimed human sequences would not have been obvious.

Combining Rinderknecht with Weissman does not fill the gap. Obviousness “cannot be established by combining the teachings of the prior art to produce the claimed invention, absent some teaching or suggestion supporting the combination.” *In re Fine*. What a reference teaches and whether it teaches toward or away from the claimed invention are questions of fact.

While Weissman discloses a general method for isolating genes, he appears to teach away from the claimed invention by emphasizing the importance of unique codons for the amino acids. Weissman suggests that it is generally advantageous to design a probe based on an amino acid sequence specified by unique codons, and also teaches that it is “counterproductive” to use a primer having more than 14–16 nucleotides unless the known amino acid sequence has 4–5 amino acids coded for by unique codons. Bell, in contrast, used a probe having 23 nucleotides based on a sequence of eight amino acids, none of which were unique. Weissman therefore tends to teach away from the claimed sequences since Rinderknecht shows that IGF-I has only a single amino acid with a unique codon and IGF-II has none.

The PTO, in urging us to affirm the Board, points to the suggestion in Weissman that the disclosed method can “easily” be applied to isolate genes for an array of proteins including peptide hormones. The PTO thus argues that in view of Weissman, a gene is rendered obvious once the amino acid sequence of its translated protein is known. We decline to afford that broad a scope to the teachings of Weissman. While “a reference must be considered not only for what it expressly teaches, but also for what it fairly suggests,” *In re Burckel* (CCPA 1979), we cannot say that Weissman “fairly suggests” that its teachings should be combined with those of Rinderknecht, since it nowhere suggests how to apply its teachings to amino acid sequences without unique codons.

We conclude that the Board clearly erred in determining that Weissman teaches toward, rather than away from, the claimed sequences. Therefore, the requisite teaching or suggestion to combine the teachings of the cited prior art references is absent and the PTO has not established that the claimed sequences would have been obvious over the combination of Rinderknecht and Weissman.

Finally, the PTO emphasizes the similarities between the method by which Bell made the claimed sequences and the method taught by Weissman. The PTO’s focus on Bell’s method is misplaced. Bell does not claim a method. Bell claims compositions, and the issue is the obviousness of the claimed compositions, not of the method by which they are made. See *In re Thorpe* (Fed. Cir. 1985) (“The patentability of a product does not depend on its method of production.”).

CONCLUSION

Because we conclude that the combination of prior art references does not render the claimed invention obvious, we reverse the Board's decision affirming the examiner's rejection of claims.

REVERSED.

Questions:

- 1.) *Bell* hints at, but never quite resolves, a fundamental question. What happens when the PHOSITA would look at a problem and say "Yes, that's a hard one but solvable. I'd try the following 1200 obvious and standard approaches and find out which one works. One of them surely will. Come back in 9 months." Does that defeat obviousness? What about the final clause of § 103? "Patentability shall not be negated by the manner in which the invention was made." Does it have any significance here?
- 2.) Who has the burden of proof on obviousness? Why?
- 3.) Teaching away: what significance does it have here?

4.) 'These Are Not the PHOSITA's you've been looking for. . . .'

Kimberly-Clark v. Johnson & Johnson
745 F.2d 1437 (Fed. Cir. 1984)



RICH, Circuit Judge.

This appeal is from the February 4, 1983, March 15, 1983 (219 USPQ 214), and April 5, 1983, 573 F. Supp. 1179, judgments of the United States District Court for the Northern District of Illinois, Eastern Division, sitting without a jury, holding that Kimberly-Clark Corporation's Roeder patent No. 3,672,371 ('371) issued June 27, 1972, for "Sanitary Napkin with Improved Adhesive Fastening Means" was not infringed, "unenforceable" because of "fraud on the PTO," and invalid under 35 U.S.C. § 103. We affirm the holding of non-infringement, reverse the holdings of obviousness and fraud, and remand. . . .

A. Who Is Presumed To Know The Prior Art

. . . Since January 1, 1953, the effective date of the 1952 Patent Act, the implementation of that social policy has not required courts to use the legal fiction that an inventor must be presumed to know the "prior art." The inventor, for the purposes of legal reasoning, has been replaced, as some courts have discovered, by the statutory hypothetical "person having ordinary skill in the art" who has been provided by 35 U.S.C. § 103. Since that date, there has been no need to presume that the inventor knows anything about the prior art.

Since we believe that progress in legal thinking is not only possible but highly desirable when it simplifies such thinking, we believe the time has come to discontinue this particular fiction of the patent law. Congress has given us in § 103 a substitute for the former "requirement for invention," which gave rise to the presumption, and that

substitute, being statutory, should be used exclusively. We hereby declare the presumption that the inventor has knowledge of all material prior art to be dead.

What controls the patentability of the fruits of the inventor's labors are the statutory conditions of novelty, utility, and unobviousness "to a person having ordinary skill in the art to which said subject matter pertains" as stated in § 103. It should be clear that that hypothetical person is not the inventor, but an imaginary being possessing "ordinary skill in the art" created by Congress to provide a standard of patentability, a descendant of the "ordinary mechanic acquainted with the business" of *Hotchkiss v. Greenwood*. Realistically, courts never have judged patentability by what the real inventor/applicant/patentee could or would do. Real inventors, as a class, vary in their capacities from ignorant geniuses to Nobel laureates; the courts have always applied a standard based on an imaginary worker of their own devising whom they have equated with the inventor.

Dan L. Burk and Mark A. Lemley,
"Is Patent Law Technology-Specific?"

17 BERKELEY TECH. L.J. 1155 (2002)



Fundamental shifts in technology and in the economic landscape are rapidly making the current system of intellectual property rights unworkable and ineffective. Designed more than 100 years ago to meet the simpler needs of an industrial era, it is an undifferentiated, one-size-fits-all system. . . . In theory, then, we have a unified patent system that provides technology-neutral protection to all kinds of technologies.

Of late, however, we have noticed an increasing divergence between the rules themselves and the application of the rules to different industries. The best examples are biotechnology and computer software. In biotechnology cases, the Federal Circuit has bent over backwards to find biotechnological inventions nonobvious, even if the prior art demonstrates a clear plan for producing the invention. On the other hand, the court has imposed stringent enablement and written description requirements on biotechnology patents that do not show up in other disciplines. In computer software cases, the situation is reversed. The Federal Circuit has essentially excused software inventions from compliance with the enablement and best mode requirements, but has done so in a way that raises serious questions about how stringently it will read the nonobviousness requirements. As a practical matter, it appears that while patent law is technology-neutral in theory, it is technology-specific in application. . . .

Much of the variance in patent standards is attributable to the use of a legal construct, the "person having ordinary skill in the art" (PHOSITA), to determine obviousness and enablement. The more skill those in the art have, the less information an applicant has to disclose in order to meet the enablement requirement—but the harder it is to meet the nonobviousness requirement. The level of skill in the art affects not just patent validity, but also patent scope. Because both claim construction and the doctrine of equivalents turn on the understanding of the PHOSITA in certain circumstances, judgments the court makes about ordinary skill in an industry affect the scope of patents that issue.

One reading of the biotechnology and computer software cases is that the Federal Circuit believes computer programmers are extremely skilled, while biotechnology experts know very little about their art. This implication is closely tied to the Federal Circuit's designation of some technologies as belonging to the "unpredictable arts"; the court treats biotechnology as if the results obtained in that art are somehow outside the

control of those of skill in the art, whereas computer science is treated as if those of skill in the art have their outcomes well in hand.

We do not challenge the idea that the standards in each industry should vary with the level of skill in that industry. We think the use of the PHOSITA provides needed flexibility for patent law, permitting it to adapt to new technologies without losing its essential character. We fear, however, that the Federal Circuit has not applied that standard properly in either the biotechnology or computer software fields. The court has a perception of both fields that was set in earlier cases but which does not reflect the modern realities of either industry. The changes in an industry over time present significant structural problems for patent law, both because law is necessarily backward-looking and precedent-bound, and because applying different standards to similar inventions raises concerns about horizontal equity. Nonetheless, we believe the courts must take more care than they currently do to ensure that their assessments of patent validity are rooted in understandings of the technology that were accurate at the time the invention was made.

Questions:

- 1.) Lemley and Burk revisited their findings in 2011 and found them largely unchanged. In light of their argument, how should we proceed? Lemley and Burk embrace the idea that judges should be sensitive to the average level of learning in a field. Is it also appropriate for judges to adjust the sophistication level of the PHOSITA deliberately to regulate the number and breadth of patents in a given area of technology? For example, could they do so if there were strong network effects that might magnify the effect of borderline patents? Did judges in software copyright cases do something similar when they defined methods of operation, fair use in the context of decompilation, or what counted as infringement? Or does this cross a line?
 - 2.) At the beginning of the course we pointed out that the Federal intellectual property system had only three pigeon holes—trademark, copyright and patent. As you look back now, would you say that we actually have technologically specific law in the following three areas: domain names in trademark, software in copyright and—if Burk and Lemley are correct—software and genetic technology in patent?
-

PROBLEM 21-1

a.) Our friend Mr. Turning, the software developer who had a tiff with Facebook, is back in your office. He has developed some new software. It proudly bears the legend “Quis Custodiet Ipsos Custodes?” or “who guards the guardians?” It allows system operators, or users, to test the security of a particular online service and to see if its password services are vulnerable to a series of the most common techniques used by hackers, but also to some new ones that Mr. Turning developed himself. In the process, Custodes will generate “test passwords” which the system administrators or legitimate users can use to validate Custodes’ findings, but which the unscrupulous could use to gain unauthorized entry to any vulnerable service. Custodes has indeed spawned a huge reaction; users have been furious to find that their private data was protected only by insecure passwords, content companies (particularly Netflix and Apple’s iTunes) have been furious to find that their material is now accessible and being illegally downloaded in massive quantities, and malicious hackers and the NSA have been furious to find this vulnerability revealed so publicly, since they had been quietly benefitting from it. The release of Custodes has prompted a wave of changes to make password systems more secure. Turning wants your advice on the possibility of patenting some of the innovations that he came up with during the process of development of Custodes.

The first thing that Turning wants to patent is a process, or algorithm, called Houdini, that can generate valid passwords far faster than normal “brute force” attacks in which every possible permutation is tried until success is achieved. The algorithm allows one to generalize from the shared characteristics of failed attempts and to “learn” from a very small number of failures, so that an entire class of passwords (e.g. those with initial capital letters) are eliminated based on “statistical hunches” and the user can move on to more promising password types. While this process does not guarantee success (the algorithm’s early “hunch” may be wrong), Houdini has been shown to be, on average, 5 times faster than a simple brute force attack. In addition, Turning wishes to patent the Custodes password-cracking program itself. It automates the process of running the Houdini algorithm and applying it to a defined web service. In your research, you find the following information.

- An industry insider tells you of a rumor that a Hungarian mathematician called von Neumann has been privately working on an identical algorithm. The project—which is shrouded in secrecy—was apparently almost entirely complete in 2011, but von Neumann has put it aside because of rapidly proliferating health problems.
- A 1993 article in the New Zealand Journal of Epidemiology reveals the possibility of statistically diagnosing underlying diseases that cause symptoms in large populations who then report those symptoms to their doctors. It does so by generalizing from small numbers of failed diagnoses, eliminating entire classes of hypothetical disease causes based on epidemiological “hunches,” and instead focusing on more promising potential diagnoses. The statistical method is similar but not identical to that employed in Houdini.
- A 2009 article in the Arizona Journal of Cryptography outlines the possibility of a computer program that “used a variety of statistical and mathematical methods” to test the security of password systems. The methods suggested were not fully described because the authors were concerned

about their possible use for criminal activity.

- Russian news reports from 2011 suggest that Russian criminal hackers use techniques that are similar but cruder than Custodes to break into secure financial systems. Because their activities are illegal, their tools are not widely available.

Can Turning patent Custodes and Houdini? In particular, are they patentable subject matter? Are they useful? Are they novel? Are they non-obvious?

b.) Your boss on the Senate Judiciary Committee wants another report. She likes “efficiency” and she wants to know why we need the novelty requirement if we have the non-obviousness requirement. One of her campaign contributors has been pressuring her on this. She forwarded you his email. It reads, “I mean, if it already *exists*, then it’s *obvious*, duh! So everything that is non-novel is, by definition, also obvious. The set of all obvious inventions includes the entire set of non-novel inventions (and a lot more). We can abolish the novelty requirement as unnecessary.” She has asked for you to draft a response listing all the reasons why we have both the non-obviousness and the novelty requirements and the reasons the two categories, while overlapping in part, are different.

Note: A Patentability Checklist

The next page contains the final checklist in the book. It goes back over all the material we have covered on patent eligibility. As before, we suggest that you use the flow charts and checklists as bookends in your review of the material, two different ways to impose structure on the legal questions that we have covered, and to make sure you have not skipped over some portion of the analysis.

The checklist identifies legal questions and points you to the cases or statutory sections we used to answer those questions. The digital version of the book has an added feature—hyperlinks that will take you directly to the material discussing the issue. As before, please use this checklist with caution. Our analysis went much deeper than any two page list can reveal. Nevertheless, we hope you find it useful.